

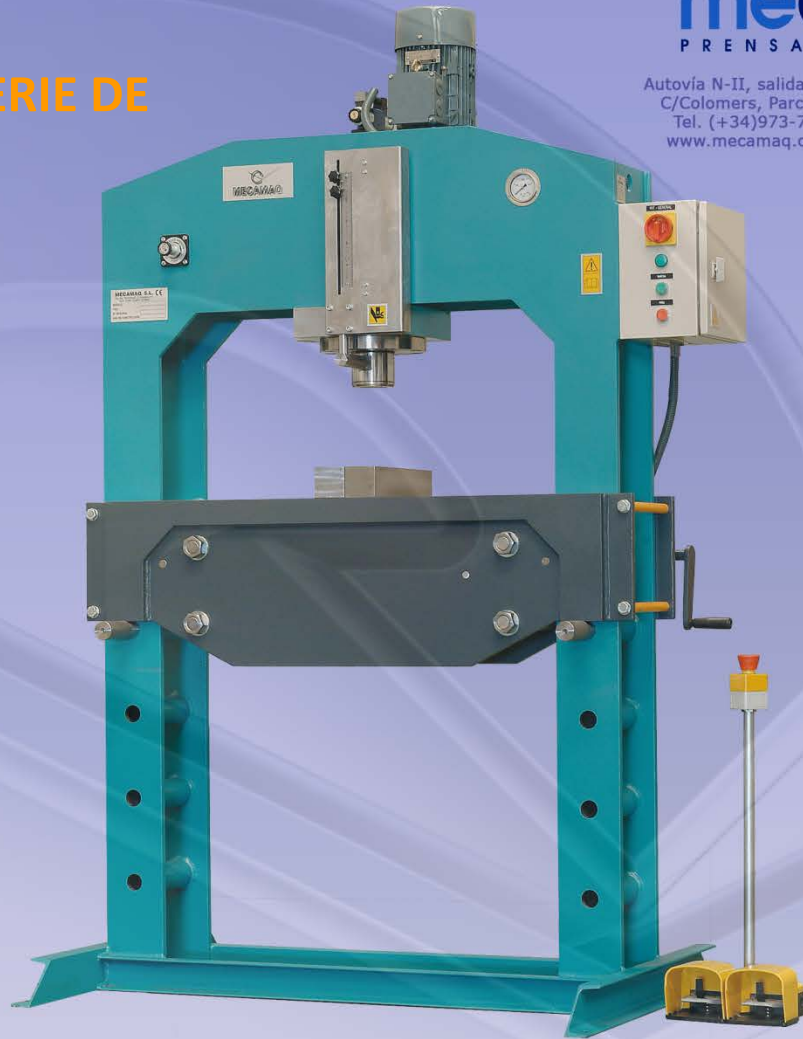

SERIE DE



mecamaq

MODEL	Power (Tm)	Stroke (mm)	Front opening (mm)	1 Speed (mm/min)	2 Speeds (mm/min)	Engine (HP/KW)	Weight (KG)
DE	70	250	1000	300	600/300	4/3	850
DE	90	250	1000	240	600/240	4/3	1000
DE	115	250	1000	190	600/190	4/3	1150

***OPTIONAL EQUIPMENT AVAILABLE:** PRESSURE REGULATOR – 2 SPEEDS HYDRAULIC SYSTEM –END OF STROKE SWITCHES AND ANTI SPIN SYSTEM – BENDING EQUIPMENT- SAFETY FRONT DOOR –REAR PROTECTION FIXED – TWO HAND SAFETY ACTIVATION– FRONT OPENING 1500mm.



mecamaq
PRENSAS HIDRÁULICAS

Autovia N-II, salida nº487-484 - Pol.Ind. "Pla d'Urgell"
C/Colomers, Parcela 9 - 25245 VILA-SANA (Lleida)
Tel. (+34)973-711281 - Fax. (+34)973-712225
www.mecamaq.com - mecamaq@mecamaq.com

DE SERIES

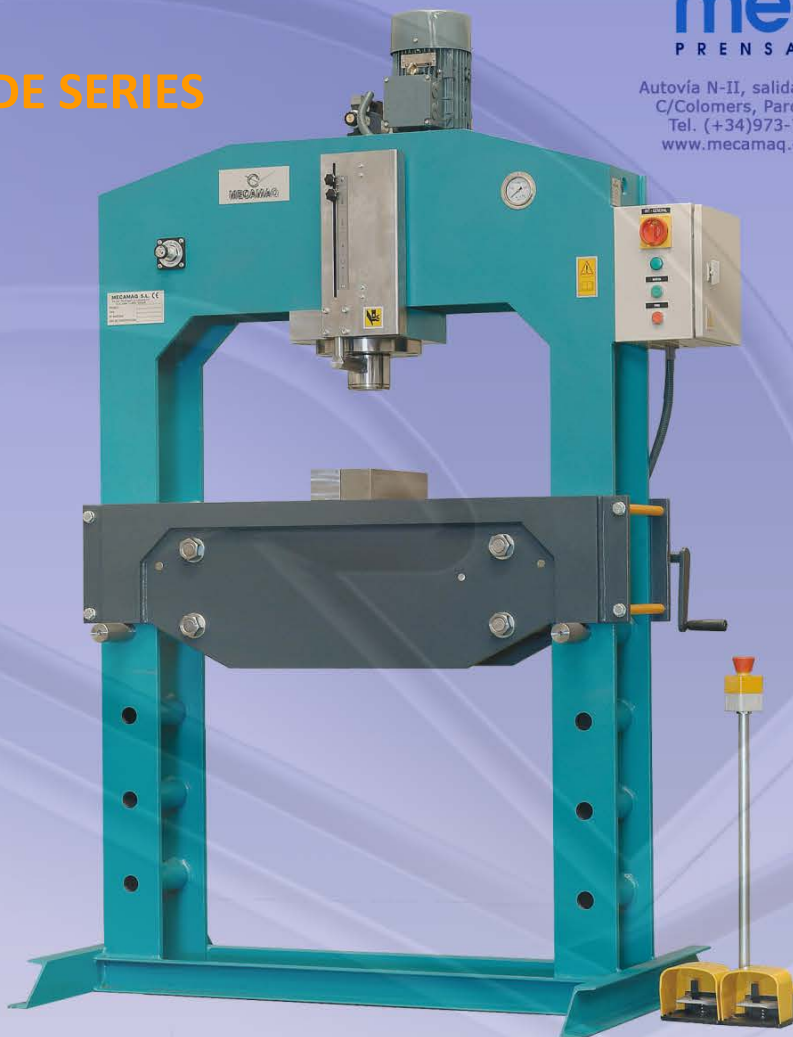

mecamaq

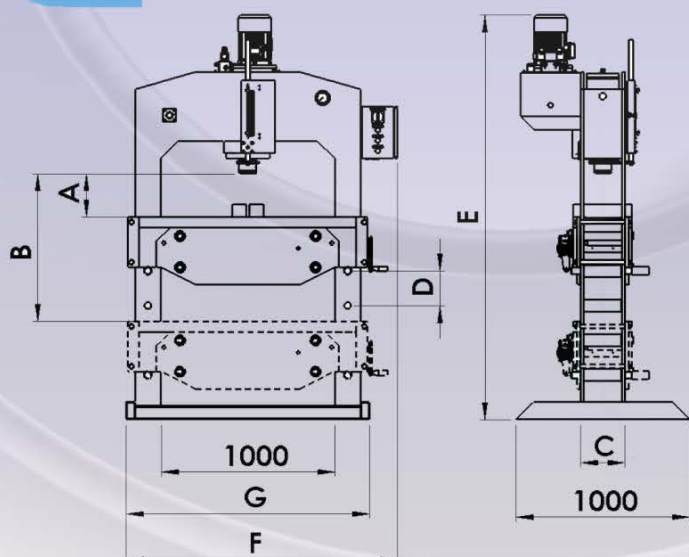

MODEL	DE	DE	DE
CAPACITY (Ton)	70	90	115
A (mm)	260	250	240
B (mm)	860	850	840
C (mm)	220	240	260
D (mm)	200	200	200
E (mm)	2340	2340	2340
F (mm)	1560	1560	1560
G (mm)	1400	1400	1400

***OPTIONAL EQUIPMENT AVAILABLE:** PRESSURE REGULATOR – 2 SPEEDS HYDRAULIC SYSTEM –LIMIT SWITCHES AND ANTI SPIN SYSTEM – BENDING EQUIPMENT – SAFETY FRONT DOOR –REAR PROTECTION FIXED –TWO HAND SAFETY ACTIVATION– FRONT OPENING 1500mm.